

RoHS compliant

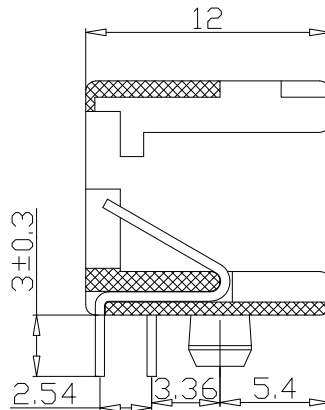

A-A

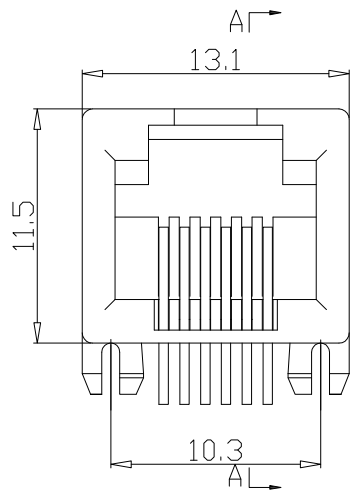
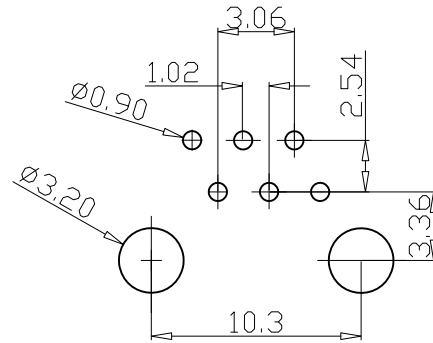
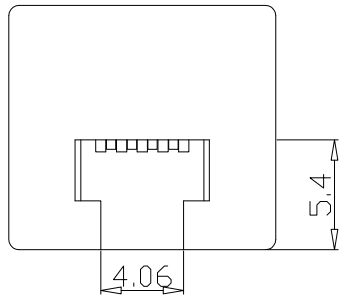

PC BOARD LAYOUT

NOTES:

ELECTRICAL:

1. VOLTAGE RATING: 125 VAC RMS.
2. CURRENT RATING: 1.5 AMP.
3. CONTACT RESISTANCE: 30 MILLIOHMS MAX.
4. INSULATION RESISTANCE: 500 MEGOHMS MIN @ 500 VDC.
5. DIELECTRIC STRENGTH: 1000 VAC RMS 50Hz or 60Hz, 1MIN.

MECHANICAL:

1. INSERT MATERIAL: UL94V-0.
2. CONTACT MATERIAL: DIAMETER 0.46MM PHOSPHOR BRONZE GOLD PLATING OVER NICKEL.
3. MATING/UNMATING FORCE: 2.2KG. F MAX.
4. RETENTION STRENGTH: 7.7KG. F MIN BETWEEN JACK AND PLUG.
5. OPERATING LIFE: 750 CYCLES MIN.

ENVIRONMENTAL:

1. STORAGE: -40°C ~ +85°C RELATIVE HUMIDITY<70%.
2. OPERATION: -40°C ~ +85°C.

Remark:

1. The mark with★ is the key inspection dimension for QC

PART NUMBER:

P/N 料号	DESCRIPTION 描述	MATER COLOR 材质
RJ53C-6611-202111	5324 MINI 1X1 6P6C 电镀GF	PBT BLACK 黑
RJ53C-6611-202115	5324 MINI 1X1 6P6C 电镀GF	PBT ORANGE 橙
RJ53C-6611-202116	5324 MINI 1X1 6P6C 电镀GF	PBT GRAY 灰
RJ53C-6611-202117	5324 MINI 1X1 6P6C 电镀GF	PBT BLUE 蓝

				GENERAL TOLERANCE	DRAWN	Gene Li	2016/07/22	UNIT	MM	X-SHUN 东莞市祥舜电子科技有限公司 DONGGUAN X-SHUN ELECTRONICTECHNOLOGY CO., LTD TEL:+86 769 81885389 FAX:+86 769 81887859 E-Mail:sales@x-shun.com Http:www.x-shun.com	
A0		NEW DESIGN	2016/07/22	.X ±0.35 X.° ±2° .XX ±0.25 X.° ±1° .XXX ±0.15 .XX° ±0.5°	CHECKE	SC		SCALE	1:1		
REV	ECN NO	DESCRIPTION	DATE	SIGNATURE	APPROVE			SHEET		PART NO.	SEE TABLE
					DRAWING NO			REV	A0	TITLE	5324 MINI 1X1 6P6C