

RoHS compliant

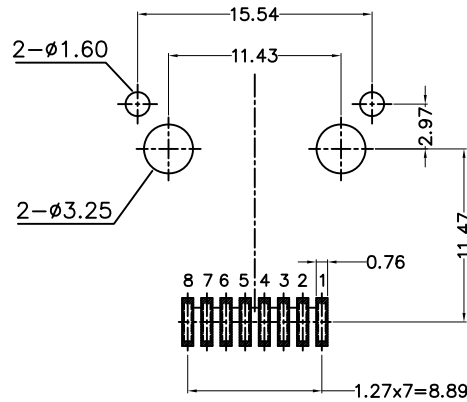
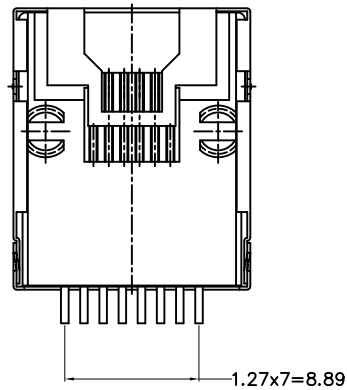
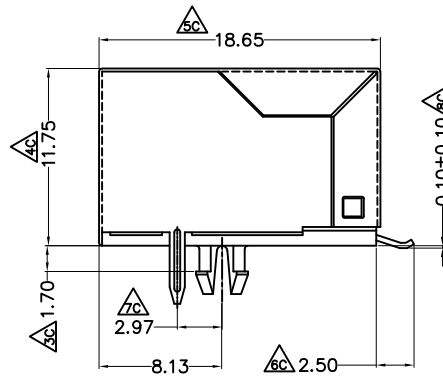
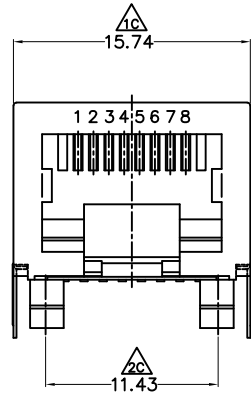

PCB LAYOUT/TOP VIEW

NOTES

- MATERIAL
- HOUSING MATERIAL : HIGH TEMP THERMOPLASTIC
FLAMMABILITY RATING UL94V-0.
 - CONTACT MATERIAL : PHOSPHOR BRONZE
 - PLATING : GOLD LATING OVER NICKEL IN CONTACT
TIN PLATING OVER NICKEL IN SOLDER AREA.
: FU", 3U", 6U", 15U", 30U", 50U".

- ELECTRICAL
- VOLTAGE RATING : 125 VAC RMS.
 - CURRENT RATING : 1.5 AMP.
 - CONTACT RESISTANCE : 40 MILLIOHMS MAX.
 - INSULATION RESISTANCE : 1000 MEGOHMS MIN @ 500V DC .
 - DIELECTRIC STRENGTH : 1000V VAC RMS 60Hz. 1MIN.

- MECHANICAL
- DURRABILITY : 750 CYCLES MIN.
 - PCB RETENTIONPRE-SOLDER : 1 LB MIN.

- ENVIRONMENTAL:
- STORAGE : -40°C~+85°C.
 - OPERATION : -20°C~+75°C.
 - IR Reflow Soldering Temperature:255°C TO 265°C.
- Mates With Modular Plug Conforming TO FCC Part 68. Subpart F.

P/N:RJ56S-8811-131551X

- GOLD PLATING
- 1-Gold Flash
 - 2-lu
 - 3-1.5u
 - 4-3u
 - 5-6u
- TAPE REEL
- 1-TAPE REEL
 - 2-PVC TRAY

REV	ECN NO	DESCRIPTION	DATE	SIGNATURE	PROJECT	DRAWING NO	REV	A0	TITLE		
A0		NEW DESIGN	2016/07/22						56 SMT RJ45 8P8C W/SHIELD JACK		
					GENERAL TOLERANCE	DRAWN	Gene Li	2016/07/22	UNIT	MM	X-SHUN 东莞市祥舜电子科技有限公司 DONGGUAN X-SHUN ELECTRONICTECHNOLOGY CO., LTD TEL:+86 769 81885389 FAX:+86 769 81887859 E-Mail:sales@x-shun.com Http:www.x-shun.com
					.X ±0.35 X.° ± 2°	CHECKE	JH		SCALE	1:1	
					.XX ±0.25 .X° ± 1°	APPROVE			SHEET	1 OF 1	
					.XXX ±0.15 .XX° ± 0.5°				PART NO.	RJ56S-8811-131551X	