

RoHS compliant

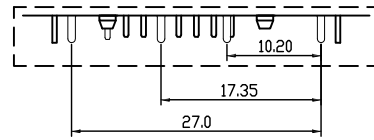

DETAL A

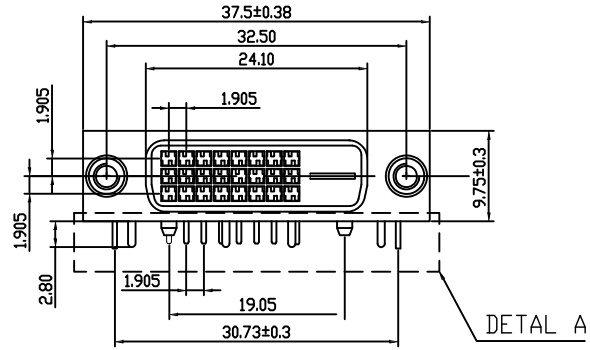
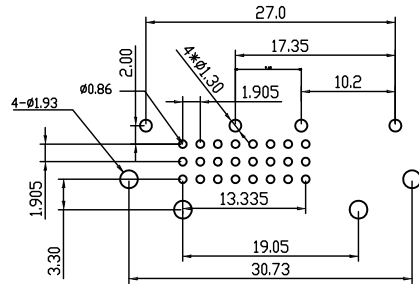
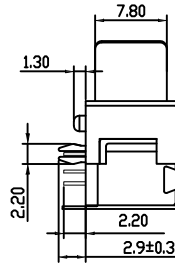
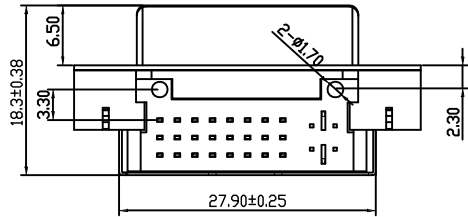

RECOMMENDED P.C.B. HOLE LAYOUT
COMPONENT SIDE VIEW (TOLERANCE: +/-0.05)

TECHNICAL REQUIREMENTS:

1. ELECTRICAL:

- CURRENT RATING: 3AMPS.
- VOLTAGE RATING: 500VAC.
- CONTACT RESISTANCE: 30mΩ MAX.
- INSULATION RESISTANCE: 1000mΩ

2. ENVIRONMENTAL:

- OPERATING TEMPERATURE: -25°C to +85°C
- STORAGE TEMPERATURE: 20°C TO 25°C

PART NAME	QTY.	MATERIAL	ITEM
SHIELDING SHELL	1	SPCC, Ni PLATING OVER ALL.	⑦
FISH FORK	2	SPCC, Tin PLATING OVER ALL.	⑥
SHELL	1	SPCC, Ni PLATING OVER ALL.	⑤
RIVET	2	COPPER ALLOY, Ni PLATING OVER ALL.	④
COVER	1	PA66+30%G. F	③
CONTACT	24	BRASS, SEMI-GOLD TIN	②
INSULATOR	1	PBT+30%G. F	①

REV	ECN NO	DESCRIPTION	DATE	SIGNATURE	PROJECT	UNIT	mm	SCALE	1:1	SHEET	REV	A0	DRAWING NO.	DVI-01
A0		NEW DESIGN	2017/05/09											
					GENERAL TOLERANCE	DRAWN		Gene Li		2017/05/09		东莞市祥舜电子科技有限公司 DONGGUAN X-SHUN ELECTRONIC TECHNOLOGY CO., LTD		
					.X ±0.35 X.° ± 2°	CHECKE		QC				PART NO. XDV1CW3-01LB0P		
					.XX ±0.25 .X° ± 1°	APPROVE						TITLE: DVI24+1 母座 卧式DIP 黑/白胶 带屏蔽壳 短柱铆合 锁螺丝		
					.XXX ±0.15 .XX° ± 0.5°									