

RoHS compliant

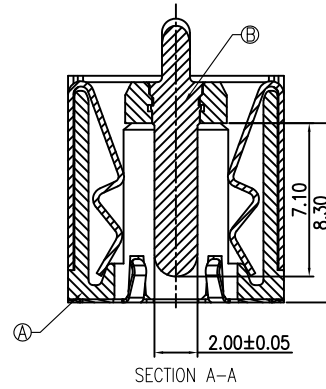

SPECIFICATION:

1. RATING: DC 30V 12A
2. CONTACT RESISTANCE:
30mΩ MAX(INITIAL).
50mΩ MAX(FINAL).
3. INSULATION RESISTANCE: 100 MΩ MIN.
4. WITHSTAND VOLTAGE: 500 VAC
5. INSERTION FORCE: 30N MAX.
6. EXTRACTION FORCE: 3N MIN.
7. DURABILITY: 5,000 CYCLES

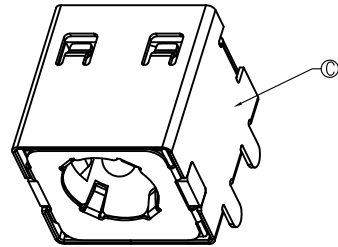
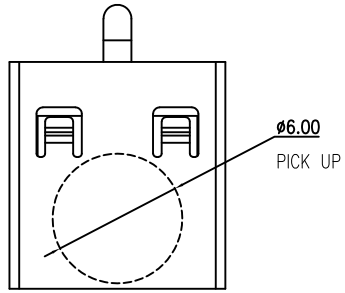
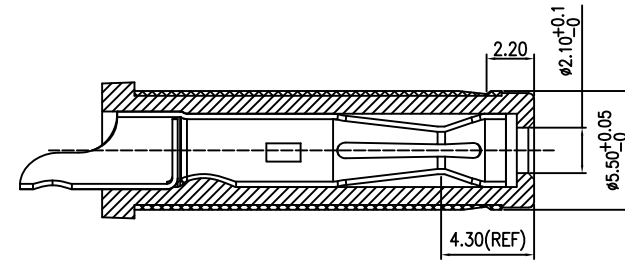
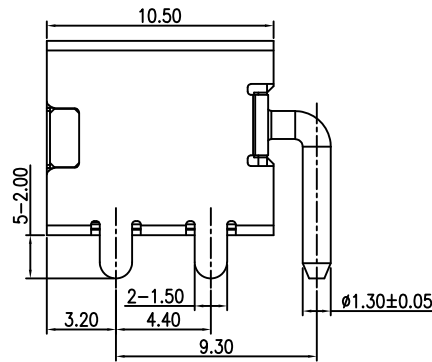
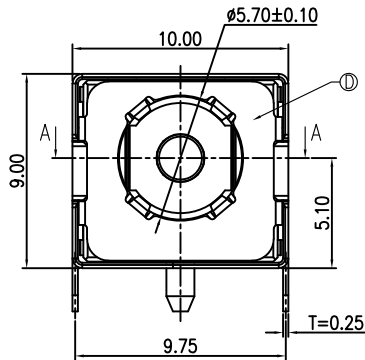

MATING PLUG
DP550200-0129-60000H

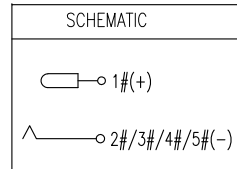
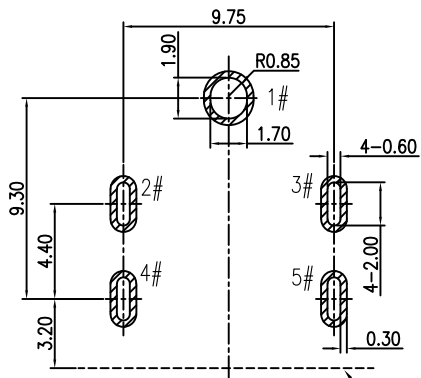

NO.	DESCRIPTION	MATERIAL	REMARKS	QTY
D	GROUND	SUS 304		1
C	SHELL	C5210	Ni 40u" MIN.	1
B	CENTER PIN	BRASS	GOLD FLASH /Ni 40u" MIN.	1
A	HOUSING	PA10T	BLACK	1

RECOMMENDED PCB LAYOUT
TOP VIEW TOLERANCE:±0.05

REV	ECN NO	DESCRIPTION	DATE	SIGNATURE	PROJECT	DRAWING NO	REV	A0	TITLE
A0		NEW DESIGN	2021/12/12						Φ5.5 卧式 DC POWER JACK

GENERAL TOLERANCE

.X	±0.35	X.°	± 2°
.XX	±0.25	.X.°	± 1°
.XXX	±0.15	.XX.°	± 0.5°

DRAWN *Sena Li* 2021/12/12

CHECKE SHZ

APPROVE

DRAWING NO

UNIT MM

SCALE 1:1

SHEET

REV A0

X-SHUN 东莞市祥舜电子科技有限公司
DONGGUAN X-SHUN ELECTRONIC TECHNOLOGY CO., LTD
TEL:+86 769 81885389 FAX:+86 769 81887859
E-Mail:sales@x-shun.com Http:www.x-shun.com

PART NO. DC550200-0982-20000H