

RoHS compliant

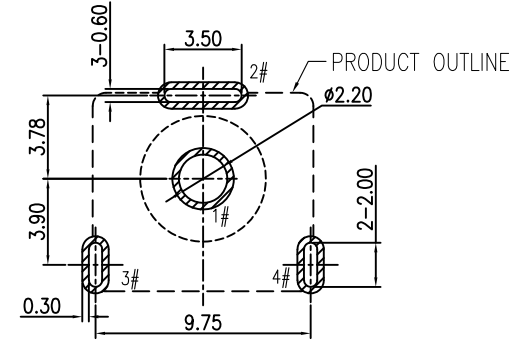

RECOMMENDED PCB LAYOUT
TOP VIEW TOLERANCE: ± 0.05

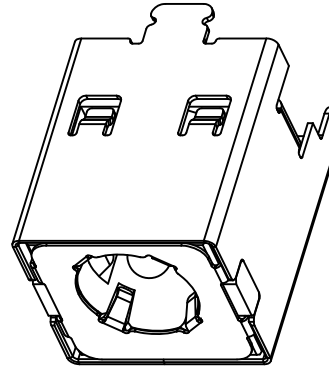
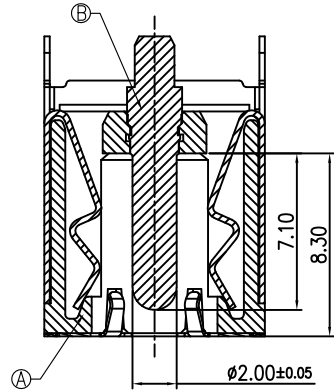
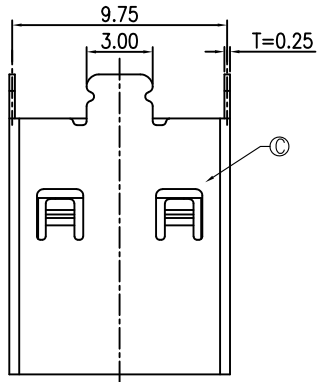
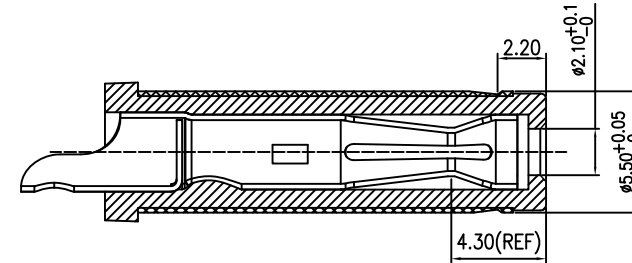
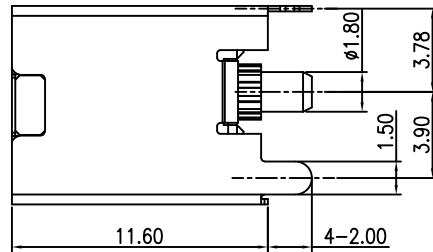
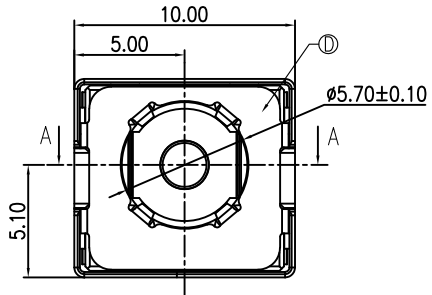

MATING PLUG
DP550200-0129-60000H

SPECIFICATION:

1. RATING: DC 20V 20A
2. CONTACT RESISTANCE:
30m Ω MAX.(INITIAL)
50m Ω MAX.(FINAL)
3. INSULATION RESISTANCE: 100 M Ω MIN.
4. WITHSTAND VOLTAGE: 500 VAC
5. INSERTION FORCE: 3N~30N
6. EXTRACTION FORCE: 3N~30N
7. DURABILITY: 5,000 CYCLES

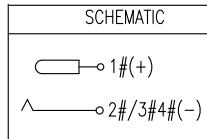

NO.	DESCRIPTION	MATERIAL	REMARKS	QTY
D	GROUND	SUS 304		1
C	SHELL	COPPER ALLOY	Ni 40u"MIN.	1
B	CENTER PIN	BRASS	GOLD FLASH/Ni 40u" MIN.	1
A	HOUSING	HIGH TEMP.THERMOPLASTIC	BLACK	1

REV	ECN NO	DESCRIPTION	DATE	SIGNATURE	PROJECT	DRAWING NO	REV	UNIT	MM	TITLE
A0		NEW DESIGN								

X-SHUN 东莞市祥舜电子科技有限公司
DONGGUAN X-SHUN ELECTRONIC TECHNOLOGY CO., LTD
TEL: +86 769 81885389 FAX: +86 769 81887859
E-Mail: sales@x-shun.com Http: www.x-shun.com

PART NO. DC550200-0986-20000H

TITLE 5.5立式 (H=11.6) DC POWER JACK