

RoHS compliant

F
E
D
C
B
A

F
E
D
C
B
A

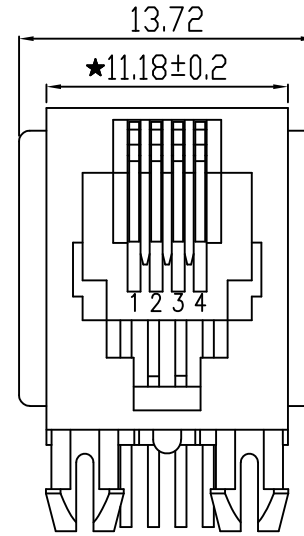
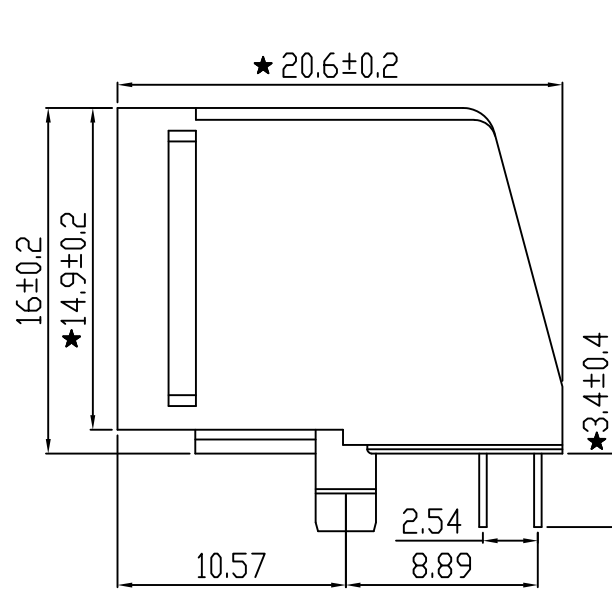
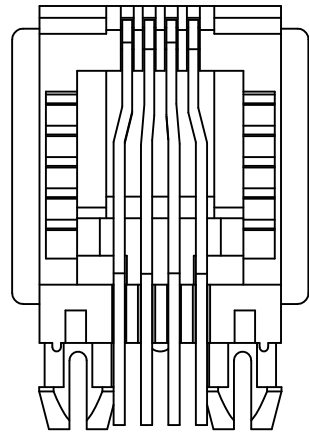

NOTES:

ELECTRICAL:

- VOLTAGE RATING: 125V AC.
- CURRENT RATING: 1.5A.
- CONTACT RESISTANCE: 30 mΩ MAX.
- INSULATION RESISTANCE: 500 MΩ MIN @ 500V DC.
- DIELECTRIC STRENGTH: 1000V AC 50Hz or 60Hz, 1MIN.

MECHANICAL:

- INSERT MATERIAL: UL94V-0.
- CONTACT MATERIAL: C5191 (QSn6.5-0.1) PHOSPHOR BRONZE T=0.35mm.
- PLATING: 1. CONTACT AREA-SELECTIVE GOLD PLATING.
2. TAILS PLATING TIN OVER NICKEL.
- MATING/UNMATING FORCE: 2.2KG. F MAX.
- RETENTION STRENGTH: 7.7KG. F MIN BETWEEN JACK AND PLUG.
- OPERATING LIFE: 600 CYCLES MIN.

ENVIRONMENTAL:

- STORAGE: -40°C ~ +85°C RELATIVE HUMIDITY<70%.
- OPERATION: -40°C ~ +85°C.

Remark:

1. The mark with★ is the key inspection dimension for QC.

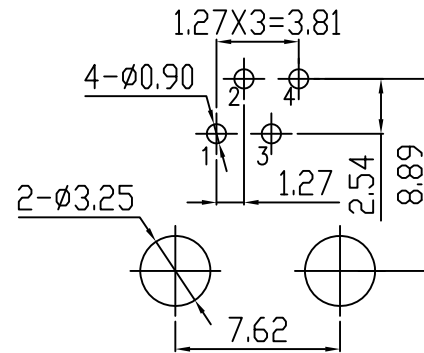
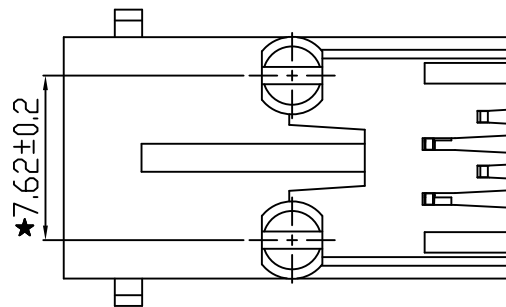

PC Board Layout

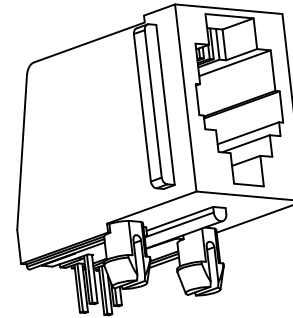

P/N:RJ57A-4411-01XXXX

GOLD PLATING	PLASTIC	COLOR	NOTE
1-Gold Flash	1-PBT	1-BLACK	X-NOTE
2-1u	2-NY66	2-WHITE	
3-1.5u	3-NY46	3-RED	
4-3u		4-YELLOW	

				GENERAL TOLERANCE		DRAWN		Gene Li		2017/03/21		东莞市祥舜电子科技有限公司 DONGGUAN X-SHUN ELECTRONIC TECHNOLOGY CO., LTD			
				.X ±0.35	X.° ± 2°	CHECKER		SC							
A0	NEW DESIGN			2017/03/21								TITLE:		5721 1X1 4P4C PCB JACK	
REV	ECN NO	DESCRIPTION	DATE	SIGNATURE	PROJECT		UNIT	mm	SCALE	1:1	SHEET	REV	A0	DRAWING NO.	H-57A-01

1 2 3 4 5 6 7 8