

RoHS compliant

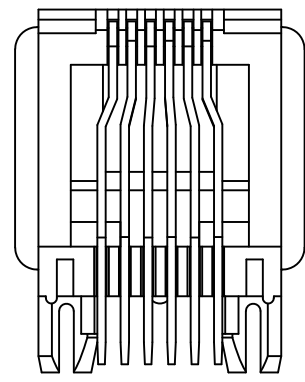

- NOTES:
- ELECTRICAL:
- VOLTAGE RATING: 125 VAC RMS.
 - CURRENT RATING: 1.5 AMP.
 - CONTACT RESISTANCE: 30 MILLIOHMS MAX.
 - INSULATION RESISTANCE: 500 MEGOHMS MIN @ 500 VDC.
 - DIELECTRIC STRENGTH: 1000 VAC RMS 50Hz or 60Hz, 1MIN.
- MECHANICAL:
- INSERT MATERIAL: UL94V-0.
 - CONTACT MATERIAL: PHOSPHOR BRONZE T=0.35MM.
 - PLATING: 1. CONTACT AREA-SELECTIVE GOLD PLATING.
: 2. TAILS PLATING TIN OVER NICKEL.
 - MATING/UNMATING FORCE: 2.2KG. F MAX.
 - RETENTION STRENGTH: 7.7KG. F MIN BETWEEN JACK AND PLUG.
 - OPERATING LIFE: 600 CYCLES MIN.
- ENVIRONMENTAL:
- STORAGE: -40°C ~ +85°C RELATIVE HUMIDITY<70%.
 - OPERATION: -40°C ~ +85°C.
- Remark:
- The mark with★ is the key inspection dimension for QC

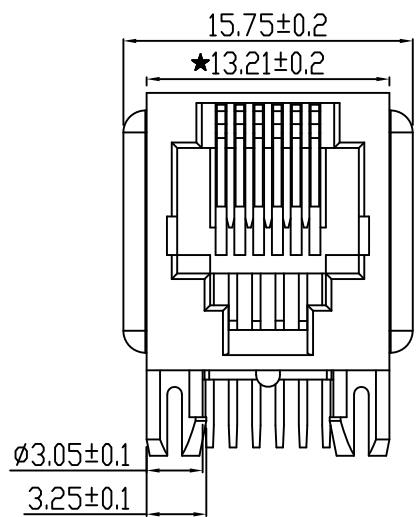
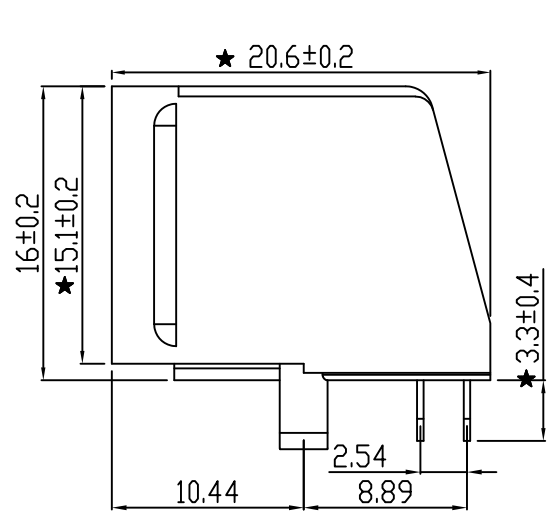
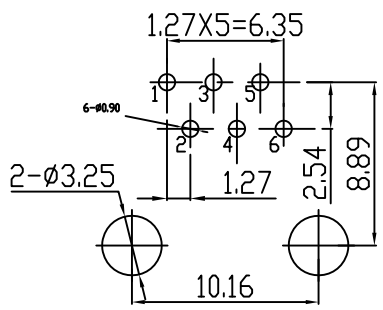
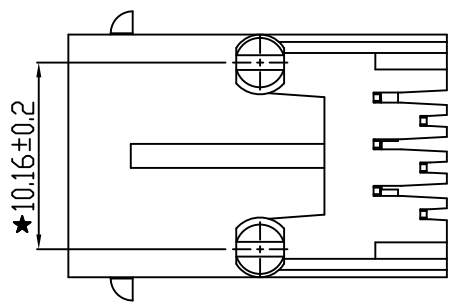

PC Board Layout

P/N:RJ57A-6611-01111X

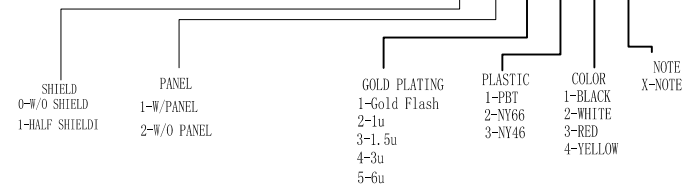

A/2		Change the drawings	2016/03/21		GENERAL TOLERANCE	DRAWN	Gene Li	2016-03-21	UNIT	MM	X-SHUN 东莞市祥舜电子科技有限公司 DONGGUAN X-SHUN ELECTRONIC TECHNOLOGY CO., LTD TEL:+86 769 81885389 FAX:+86 769 81887859 E-Mail:sales@x-shun.com Http:www.x-shun.com	
A/1		Change the drawings	2014/11/17		.X ±0.25 X.° ± 2°	CHECKE	SC		SCALE	1:1		
A0		NEW DESIGN	2014/04/12		.XX ±0.20 .X.° ± 1°	APPROVE			SHEET	1 OF 1	PART NO.	RJ57A-6611-01111X
REV	ECN NO	DESCRIPTION	DATE	SIGNATURE	.XXX ±0.10 .XX.° ± 0.5°	DRAWING NO			REV	A0	TITLE	5721-6P6C-E W/PANEL