

RoHS compliant

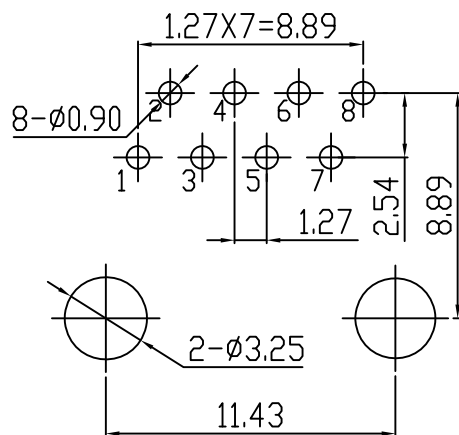
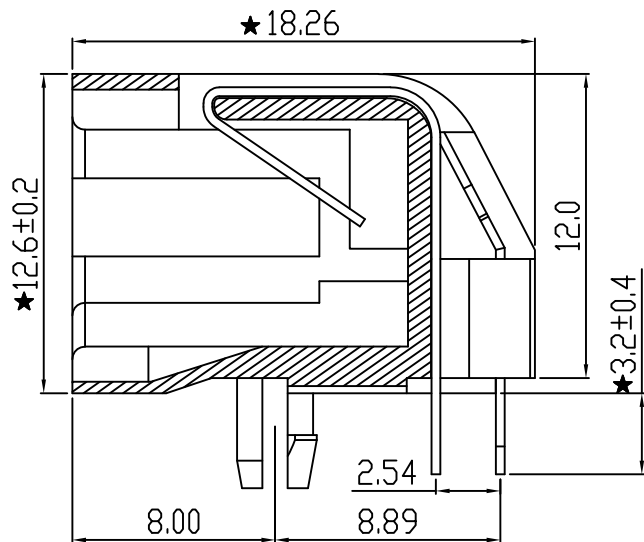
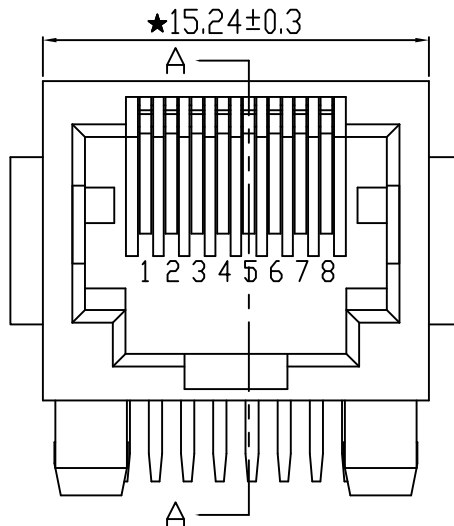
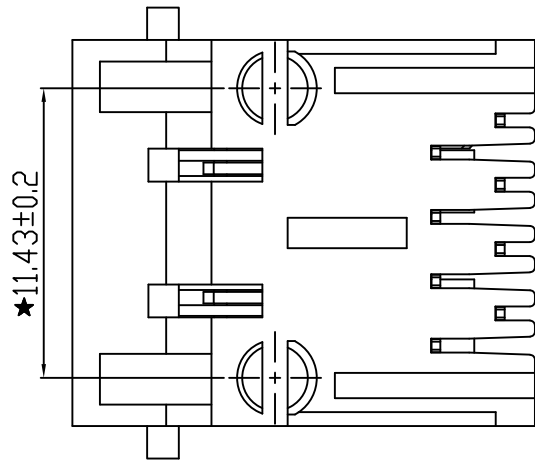

PC Board Layout

NOTES:

ELECTRICAL:

- VOLTAGE RATING: 125V AC.
- CURRENT RATING: 1.5A.
- CONTACT RESISTANCE: 30 mΩ MAX.
- INSULATION RESISTANCE: 500 MΩ MIN @ 500V DC.
- DIELECTRIC STRENGTH: 1000V AC 50Hz or 60Hz, 1MIN.

MECHANICAL:

- INSERT MATERIAL: UL94V-0.
- CONTACT MATERIAL: C5191 (QSn6.5-0.1) PHOSPHOR BRONZE T=0.35mm.
- PLATING: 1. CONTACT AREA-SELECTIVE GOLD PLATING.
2. TAILS PLATING TIN OVER NICKEL.
- MATING/UNMATING FORCE: 2.2KG.F MAX.
- RETENTION STRENGTH: 5.0KG.F MIN BETWEEN JACK AND PLUG.
- OPERATING LIFE: 600 CYCLES MIN.

ENVIRONMENTAL:

- STORAGE: -40°C ~ +85°C RELATIVE HUMIDITY<70%.
- OPERATION: -40°C ~ +85°C.

Remark:

- The mark with★ is the key inspection dimension for QC.

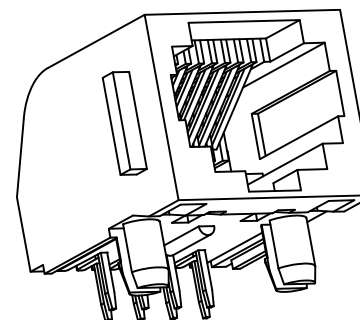

P/N:RJ57B-8811-01111X

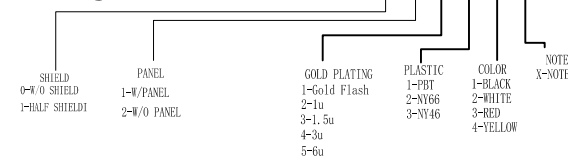

				GENERAL TOLERANCE		DRAWN	<i>Gene Li</i>	2017/09/12	UNIT	MM	东莞市祥舜电子科技有限公司 DONGGUAN X-SHUN ELECTRONICTECHNOLOGY CO., LTD TEL:+86 769 81885389 FAX:+86 769 81887859 E-Mail:sales@x-shun.com Http:www.x-shun.com	
				.X ±0.25	X.° ±2°	CHECKE	SC		SCALE	1:1		
				.XX ±0.20	.X° ±1°	APPROVE			SHEET	1 OF 1		
A0		NEW DESIGN	2017/09/12	.XXX ±0.10	.XX° ±0.5°				PART NO.	RJ57B-8811-01111X		
REV	ECN NO	DESCRIPTION	DATE	SIGNATURE	PROJECT	DRAWING NO			REV	A0	TITLE	5722 1X1 8P8C-E