

RoHS compliant

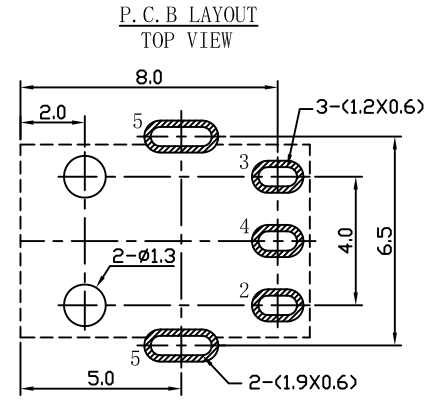

SCHEMATIC

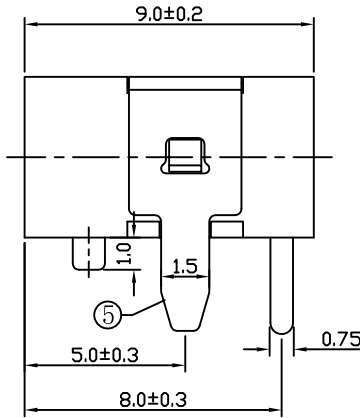
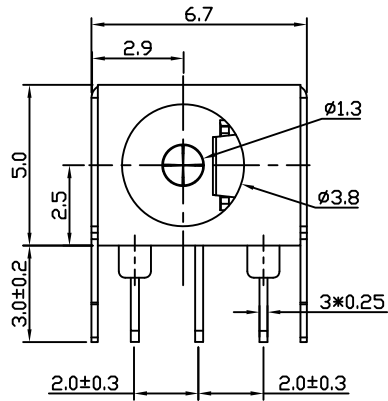
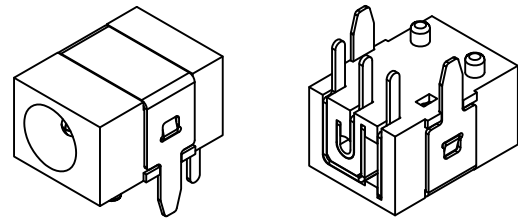
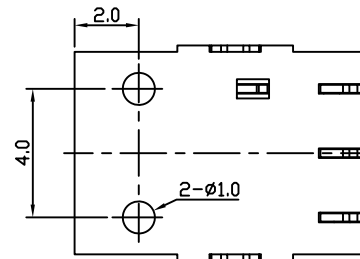
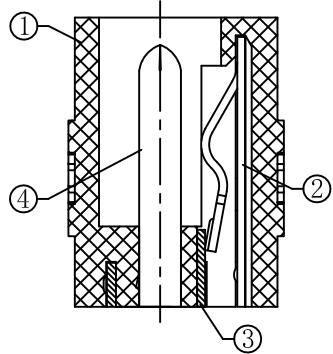
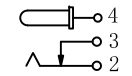

SPECIFICATION

1. Rating : DC 30V 2.0A;
2. Contact resistance: $\leq 0.05 \Omega$;
3. Insulation resistance: $\geq 100M \Omega$ (DC250V);
4. Withstand voltage: 500VAC ;
5. Insertion and extraction force: 3-20N;
6. life test: 5,000 cycles.

5	COAT	1	BRASS	Ag-Plating
4	PIN	1	BRASS	Ag-Plating
3	CURVE PIECE	1	BRASS	Ag-Plating
2	SPRING	1	SUS301	Ag-Plating
1	HOUSING	1	PA9T	
NO.	DESCRIPTION	QTY	MATERIAL	PLATING

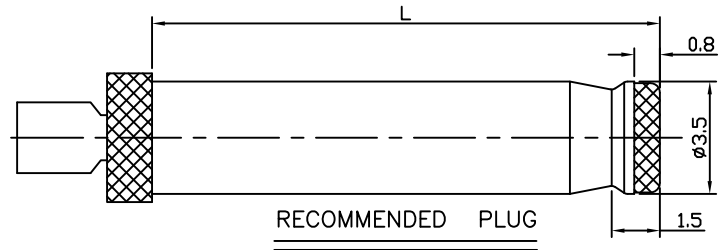

					GENERAL TOLERANCE		DRAWN		Gene Li		2019/12/08		X-SHUN 东莞市祥舜电子科技有限公司 DONGGUAN X-SHUN ELECTRONIC TECHNOLOGY CO., LTD			
					.X ±0.35	X.° ± 2°	CHECKE		JHS							
A0					NEW DESIGN		2019/12/08						TITLE: DC POWER JACK			
REV	ECN NO	DESCRIPTION	DATE	SIGNATURE	PROJECT		UNIT	mm	SCALE	1:1	SHEET	1/1	REV	A0	DRAWING NO.	DC-016